

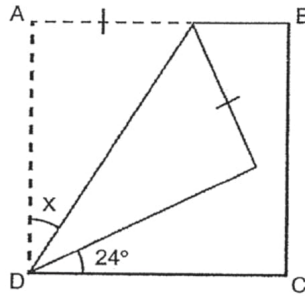

16. Square ABCD is folded to form the figure below. Find  $\angle x$ .



- (1)  $12^\circ$
- (2)  $24^\circ$
- (3)  $33^\circ$
- (4)  $66^\circ$

17. In the figure, ABCD is a square and EFGA is a rectangle.  
The length of EF is 3 times the length of FG,  $FG = 8$  cm and  $AD = 7$  cm.  
Find the length of BG.

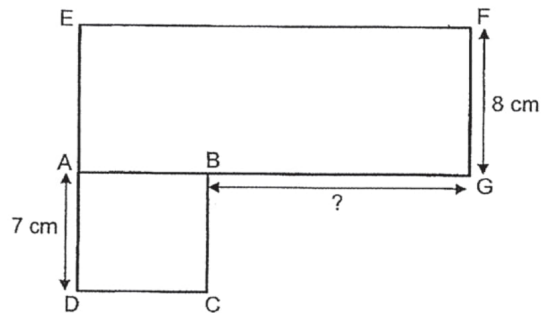

- (1) 16 cm
- (2) 17 cm
- (3) 21 cm
- (4) 24 cm



**MARIS STELLA HIGH SCHOOL (PRIMARY)**

**SEMESTRAL ASSESSMENT 1**

**Primary 4 MATHEMATICS**

**14 MAY 2019**

**BOOKLET A**

20 questions

40 marks

Total Time For Booklets A and B: 1 h 45 min

**NAME :** \_\_\_\_\_ (    )

**CLASS :** PRIMARY 4 \_\_\_\_\_

**DO NOT OPEN THIS BOOKLET UNTIL YOU ARE TOLD TO DO SO.**

**FOLLOW ALL INSTRUCTIONS CAREFULLY.**

**ANSWER ALL QUESTIONS.**

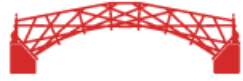

**Dr.Kenny Education**

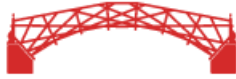

## Section A (20 x 2 = 40 marks)

For each question, four options are given. One of them is the correct answer. Make your choice (1, 2, 3 or 4). Shade the correct oval (1, 2, 3 or 4) on the Optical Answer Sheet.

---

1. Which one of the following is the same as 62 409?
  - (1)  $6\ 000 + 200 + 40 + 9$
  - (2)  $60\ 000 + 2000 + 40 + 9$
  - (3)  $60\ 000 + 2000 + 400 + 9$
  - (4)  $60\ 000 + 2000 + 200 + 9$
  
2. Round 55 825 to the nearest thousand.
  - (1) 55 000
  - (2) 55 800
  - (3) 55 900
  - (4) 56 000
  
3. An odd number when rounded to the nearest hundred is 2800. The smallest possible value of this odd number is \_\_\_\_\_.
  - (1) 2750
  - (2) 2751
  - (3) 2753
  - (4) 2755
  
4. Which of the following statement is correct?
  - (1) 7 is a factor of 28
  - (2) 12 is a multiple of 8
  - (3) 3 is a common factor of 18 and 32
  - (4) 24 is a common multiple of 6 and 14



5. Which of the following pairs of numbers are multiples of 8?

- (1) 2 and 4
- (2) 24 and 53
- (3) 36 and 64
- (4) 48 and 72

6. What is the missing number of **A** and **B** in the number pattern?

23 723, 24 623, \_\_\_\_\_ **A** \_\_\_\_\_, \_\_\_\_\_ **B** \_\_\_\_\_, 27 323

- (1) 24 523 , 25 423
- (2) 24 533 , 25 623
- (3) 25 523 , 26 423
- (4) 25 723 , 26 323

7. \_\_\_\_\_  $\div$  4 = 3795 R2

- (1) 7590
- (2) 7594
- (3) 15 180
- (4) 15 182

8. Mr Koh's age is between 35 and 55. His son's age is a factor of 30.  
If Mr Koh is 6 times his son's age, how old is his son?

- (1) 5
- (2) 6
- (3) 3
- (4) 10

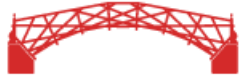

9. Which pair of angle strips below shows a turn between a  $\frac{1}{2}$ -turn and a  $\frac{3}{4}$ -turn?

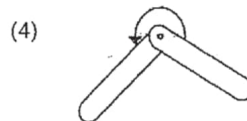
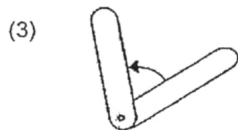
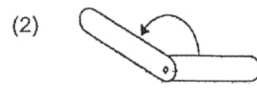
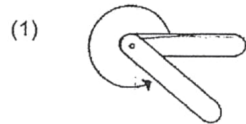

10. How many of the numbers below have a line of symmetry?

**2 0 1 9**

- (1) 1  
(2) 2  
(3) 3  
(4) 4
11. A machine can produce 7680 toys in 8 hours.  
How many toys can the machine produce in one hour?
- (1) 480  
(2) 960  
(3) 1920  
(4) 3840



12. Which of the dotted lines is a line of symmetry?

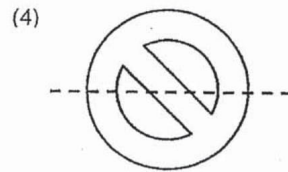
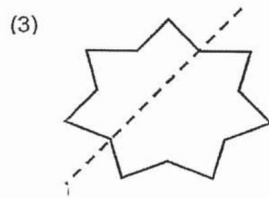
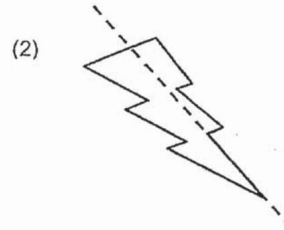
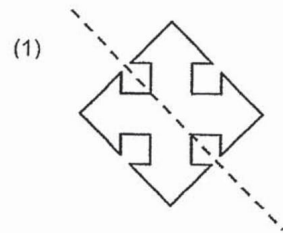

13. Which one of the following angles is  $65^\circ$ ?

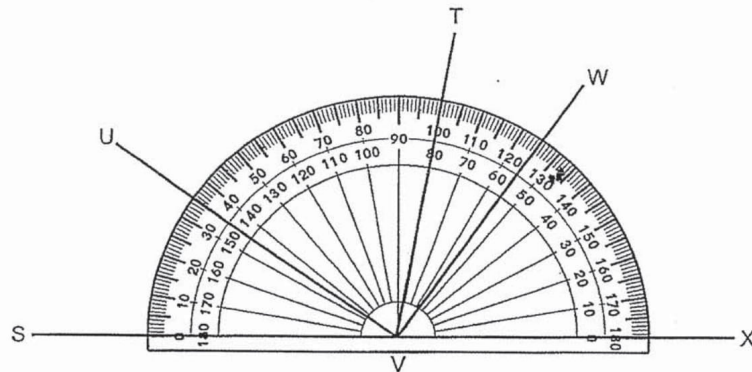

- (1)  $\angle SVU$
- (2)  $\angle TVU$
- (3)  $\angle UWV$
- (4)  $\angle XVW$



14. Robin is standing in the centre at Point R facing Suntec City.

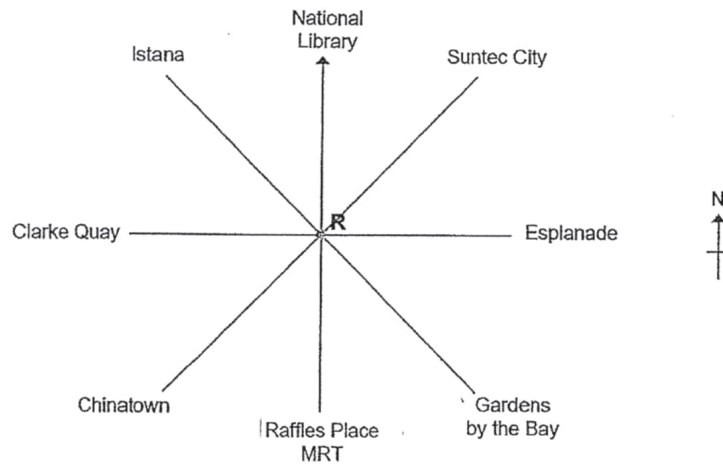

If he makes a \_\_\_\_\_ - turn in the \_\_\_\_\_ direction, he will face Istana.

- (1)  $\frac{1}{4}$ , clockwise
- (2)  $\frac{1}{2}$ , clockwise
- (3)  $\frac{1}{4}$ , anti-clockwise
- (4)  $\frac{3}{4}$ , anti-clockwise

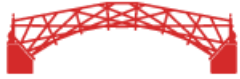

15. A piece of cloth is used to cover half of a symmetric pattern as shown below.

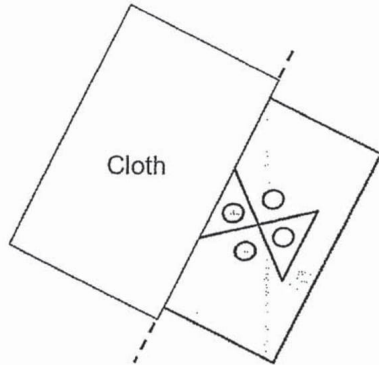

Which of the following shows the correct symmetric pattern when the cloth is removed?

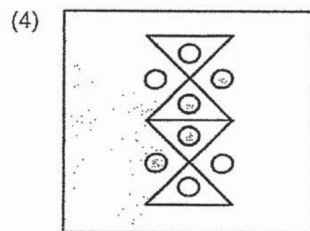
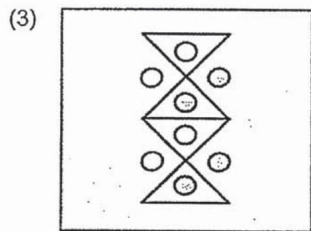
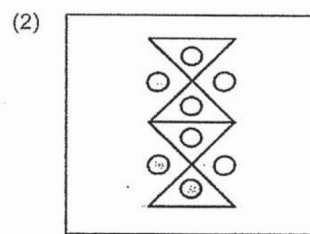
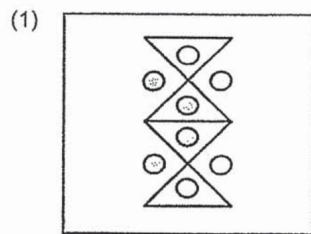



18. A class is playing an "input-output" game. Each student is to choose an "input" number and then use the rule below to work out the "output" number.

**"Input-output" Rule**  
Add 2 to the input number  
Multiply the sum by 8 to get the output number

The table below shows the "input" number and the "output" number calculated by four students. Which student gave the **wrong** "output" number?

Name of Students	"Input" Number	"Output" number
Alan	4	48
Benny	20	176
Candice	9	74
Doris	7	72

- (1) Alan
  - (2) Benny
  - (3) Candice
  - (4) Doris
19. A drink stall sold 478 canned drinks on Saturday. It sold 3 times as many canned drinks on Sunday than on Saturday. How many canned drinks did the stall sell on both days?
- (1) 1434
  - (2) 1882
  - (3) 1902
  - (4) 1912



20. Edmund has \$190 in his wallet. They are all \$2 and \$5 notes.  
There were 4 more \$2 notes than \$5 notes.  
How many \$2 notes does Edmund have?

- (1) 26
- (2) 30
- (3) 91
- (4) 95

**End of Booklet A**  
**Go on to Booklet B**



**MARIS STELLA HIGH SCHOOL (PRIMARY)**

**SEMESTRAL ASSESSMENT 1**

**Primary 4 MATHEMATICS**

**14 MAY 2019**

**BOOKLET B**

25 questions

60 marks

Total Time For Booklets A and B: 1 h 45 min.

**NAME :** \_\_\_\_\_ (     )

**CLASS :** PRIMARY 4 \_\_\_\_\_

**DO NOT OPEN THIS BOOKLET UNTIL YOU ARE TOLD TO DO SO.**

**FOLLOW ALL INSTRUCTIONS CAREFULLY.**

**ANSWER ALL QUESTIONS.**

**MARKS OBTAINED :**

**BOOKLET A:** \_\_\_\_\_ / 40

**BOOKLET B:** \_\_\_\_\_ / 60

**TOTAL :** \_\_\_\_\_ / 100



Section B (20 x 2 = 40 marks)

Show your working clearly in the spaces below each question and write your answers in the spaces provided. For questions which require units, give your answers in the units stated.

21. Write the number represented by the number discs.

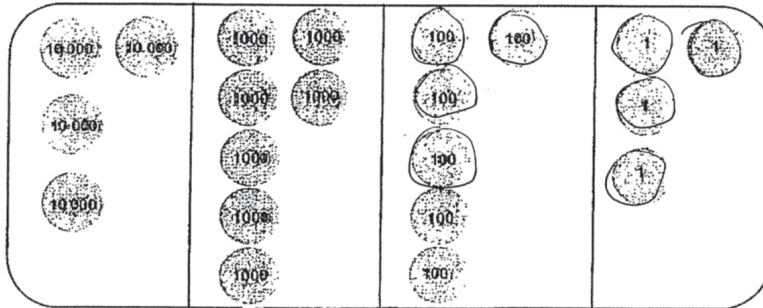

Do not write in this space.

Answer: \_\_\_\_\_

22. Find the product of 328 and 45.

Answer: \_\_\_\_\_

23. What is the difference between the 7<sup>th</sup> multiple of 8 and the 3<sup>rd</sup> multiple of 9?

Answer: \_\_\_\_\_

--

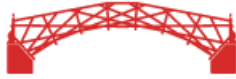

24. A number is between 20 and 40. It is a multiple of 6.  
When it is divided by 5, the remainder is 1.  
What is the number?

Do not  
write in  
this  
space.

Answer: \_\_\_\_\_

25. Study the four numbers below carefully.

46 338

46 833

64 383

64 833

Based on the numbers given, each of the following statements is either **True** or **False**. For each statement, put a tick (✓) in the correct column to indicate your answer.

		True	False
(a)	The difference between the greatest and the smallest number is 18 495.		
(b)	The following numbers are arranged in decreasing order.		

26. Use the following clues to find the **smallest** 5-digit number.

- All the digits are made up of different even digits.
- The digit in the ones place is twice the digit in the tens place.
- The digit in the hundreds place is 4 more than the digit in the ten thousands place.

Answer: \_\_\_\_\_

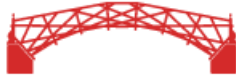

27. 4 dining tables cost as much as 3 sofas.  
Each sofa costs \$3296. How much is a dining table?

Do not  
write in  
this  
space.

Answer: \$ \_\_\_\_\_

28. Pauline has less than 70 seashells. If she packs all the seashells in bags of 9, she will have 4 seashells left unpacked. If she packs all the seashells in bags of 7, she will have no seashells left unpacked. How many seashells does Pauline have?

Answer: \_\_\_\_\_

29. Mr Vincent had 292 beads. After giving 7 beads to each student in his class, he had 26 beads left. How many students were there in his class?

Answer: \_\_\_\_\_

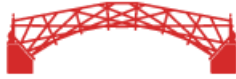

30. Draw a line on the protractor below to show  $\angle ABC = 85^\circ$ . Label the line.

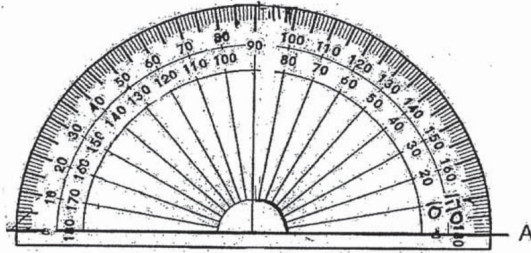

Do not write in this space.

31. Complete the symmetric figure using the dotted line as a line of symmetry.

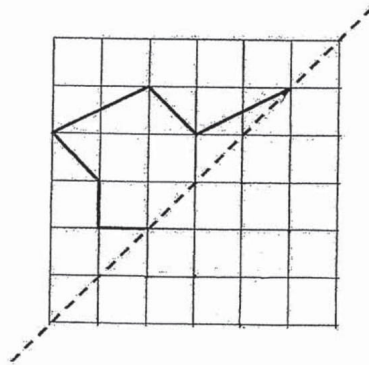

32. Complete the rectangle below by drawing in the two missing lines.

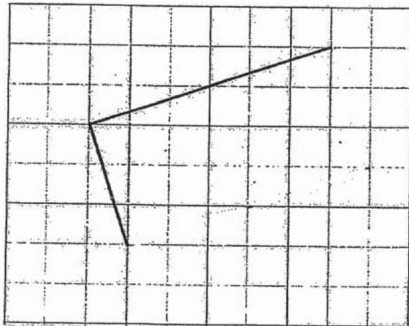

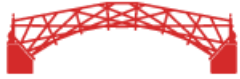

33. Jug A, Jug B and Jug C had a total of 1096 ml of apple juice.  
There were twice as much apple juice in Jug A than Jug C.  
There were 232 ml more apple juice in Jug B than Jug C.  
How much apple juice was there in Jug C?

Answer: \_\_\_\_\_ ml

34. Evan bought a total of 20 chicken pies and curry puffs for \$56. Each curry puff cost \$2 and each chicken pie cost \$4. How many chicken pies did he buy?

Answer: \_\_\_\_\_

35. The cost of a blouse and a dress is \$41.  
The cost of 4 similar blouses and 3 similar dress is \$140.  
Find the cost of a blouse.

Answer: \$ \_\_\_\_\_



36. The figure is made up of two rectangles, RSTU and QWVP.  $RS = 20$  cm,  $PV = 24$  cm and  $QU = UW$ . Find the length of WT.

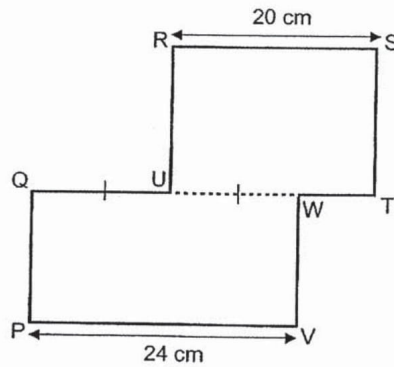

Do not write in this space.

Answer: \_\_\_\_\_ cm

37. ABCD is a square and EFHC is a rectangle.  $\angle FCG = 18^\circ$  and  $\angle GCH = 42^\circ$ . Find  $\angle ACF$ .

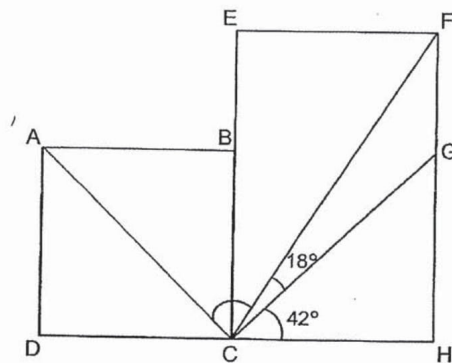

Answer: \_\_\_\_\_ °



38. John has 3 times as many stamps as Peter. If John gives Peter 40 stamps, he will have the same number of stamps as Peter. How many stamps do John and Peter have altogether?

Do not write in this space.

Answer: \_\_\_\_\_

39. Some balloons are tied to a fence. They are 4 m apart from each other as shown below. The fence is 32 m long. How many balloons are tied to the fence?

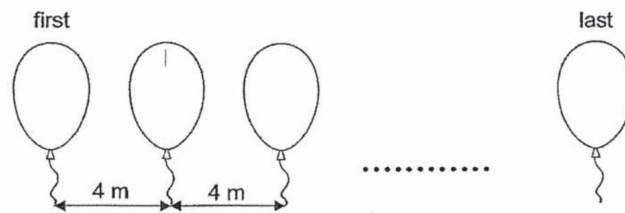

Answer: \_\_\_\_\_

40. Lisa had 788 more beads than James. After Lisa gave away 68 beads, she had 4 times as many beads as James. How many beads did James have?

Answer: \_\_\_\_\_

--



**Section C ( 5 x 4 = 20 marks )**

Work out the answers for each of the following questions. All workings must be shown clearly in the space provided.

41. Timothy has 49 boxes of stickers.  
There are 35 stickers in each box.  
He repacks all the stickers into packets of 8 stickers each.
- (a) How many packets, each containing 8 stickers, can Timothy get?  
(b) How many stickers are left unpacked?

Do not  
write in  
this  
space.

Answer: (a) \_\_\_\_\_ [2]

(b) \_\_\_\_\_ [2]

--



42. Bernard had 1360 marbles and Ronald had 4970 marbles.  
Ronald gave some marbles to Bernard.  
In the end, Bernard had twice as many marbles as Ronald.
- (a) How many marbles did Ronald have in the end?
  - (b) How many marbles did Ronald give Bernard?

Do not  
write in  
this  
space.

Answer:(a)\_\_\_\_\_ [2]

(b)\_\_\_\_\_ [2]



43. In the figure below, ABEF is a rectangle and FECD is a square. X, Y and Z are 3 identical squares inside square FECD. AF is 2 cm and the side of square Z is 4 cm.

- (a) Find the length of AD.  
(b) Find the area of square FECD.

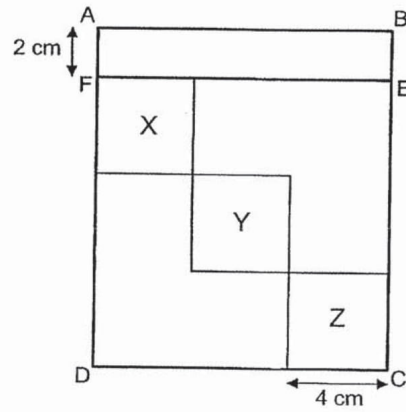

Do not write in this space.

Answer:(a) \_\_\_\_\_ [2]

(b) \_\_\_\_\_ [2]



44. George made a pattern using toothpicks. The first 3 figures are shown below.

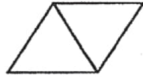

Figure 1

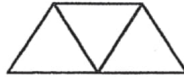

Figure 2

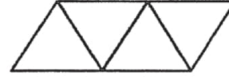

Figure 3

Do not write in this space.

Figure	Number of toothpicks used
1	5
2	7
3	9
⋮	⋮
⋮	⋮
⋮	⋮

- (a) How many toothpicks did George use for **Figure 10**?
- (b) Which figure did George use **151** toothpicks to make?

Show your workings clearly below.

Answer: (a) \_\_\_\_\_ [2]

(b) Figure \_\_\_\_\_ [2]

--

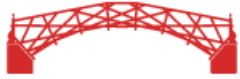

45. Paul, Zach and Quentin saved \$1016 in total. Zach saved \$85.  
Quentin saved 3 times as much as the total saved by Paul and Zach.  
How much did Paul save?

Do not  
write in  
this  
space.

Answer: \_\_\_\_\_ [4]

**END OF PAPER**

SCORE

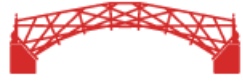

**Dr.Kenny Education**



### ANSWER KEY

YEAR : 2019  
LEVEL : PRIMARY 4  
SCHOOL : MARIS STELLA HIGH SCHOOL (PRIMARY)  
SUBJECT : MATHEMATICS  
TERM : SA1

#### PAPER ONE : BOOKLET A

Q1	Q2	Q3	Q4	Q5	Q6	Q7	Q8	Q9	Q10
3	4	2	1	4	3	4	2	4	1
Q11	Q12	Q13	Q14	Q15	Q16	Q17	Q18	Q19	Q20
2	1	2	3	1	3	2	3	4	2

#### PAPER ONE : BOOKLET B

Q21	47 604
Q22	14 760
Q23	$(7 \times 8) - (3 \times 9) = 56 - 27 = 29$
Q24	36
Q25	(a) True (b) False
Q26	20 648
Q27	$\$3296 \times 3 = \$9888$ $\$9888 \div 4 = \$2472$
Q28	49
Q29	$292 - 26 = 266$ $266 \div 7 = 38$
Q30	
Q31	



Q32	
Q33	$A : B : C \rightarrow 2u : 1u + 232 : 1u$ $1096 - 232 = 864$ $864 \div 4 = 216$ Answer : 216ml
Q34	Assume 20 puffs $\rightarrow \$2 \times 20 = \$40$ Diff cost btw Evan and 20 puffs $\rightarrow \$56 - \$40 = \$16$ Diff btw pies and puffs $\rightarrow \$4 - \$2 = \$2$ No of pie Evan bought $\rightarrow \$16 \div \$2 = 8$ Answer: 8 pies
Q35	$1B + 1D = \$41$ $3B + 3D = \$41 \times 3 = \$123$ $4B + 3D = \$140$ $1B = \$140 - \$123 = \$17$ Answer : \$17
Q36	$UW = 24 \div 2 = 12$ $WT = 20 - 12 = 8\text{cm}$
Q37	$\angle ECF = 90 - 18 - 42 = 30$ $\angle ACF = 30 + 45 = 75$
Q38	$1u \rightarrow 40$ $4u \rightarrow 40 \times 4 = 160$
Q39	$32 \div 4 = 8$ $8 + 1 = 9$
Q40	Diff between Lisa and James $\rightarrow 788 - 68 = 720$ Beads James have $\rightarrow 720 \div 3 = 240$
Q41	$49 \times 35 = 1715$ $1715 \div 8 = 214 \text{ R } 3$ (a) 214 (b) 3
Q42	Total $\rightarrow 4970 + 1360 = 6330$ Divide to 3u $\rightarrow 6330 \div 3 = 2110$ (a) Ronald have 2110 marbles. $4970 - 2110 = 2860$ (b) Ronald give 2860 marbles.



Q43	$FD = 4 \times 3 = 12$ $AD = 12 + 2 = 14$ (a) 14 cm $12 \times 12 = 144$ (b) 144cm <sup>2</sup>
Q44	$10 \times 2 = 20$ $20 + 3 = 23$ (a) 23 $151 - 3 = 148$ $148 \div 2 = 74$ (b) Figure 74
Q45	$Z \rightarrow 85$ $P : Z : Q \rightarrow P : 85 : 3P + (3 \times 85)$ $85 \times 4 = 340$ $1016 - 340 = 676$ $4P \rightarrow 676 \div 4 = 169$ Answer : \$169

3  
2ND.